

MT5HV11AC

Standard Pad Spread: 22½" x 46" [572 x 1168 mm]
 Number / Size of Pads: 5 / 10" [254 mm] dia. lipped
 Load Capacity: 800 lbs. [365 kg]

(On smooth, nonporous surfaces.
 Please contact us for recommendations on other surfaces.)

Unit Weight: 101 lbs. [46 kg]
 Standard Operating Power: 120 volts AC, 60 hertz, 5 amps
 (240 volts AC, 60 hertz, 3 amps also available)
 Apply: 3 sec. Release: 3 sec. (approx.)
 Load Movement: Manual tilt, 90° between upright and flat
 Twist-lock electrical plug
 Spring-mounted pads
 Vacuum gauge
 Vacuum line filter
 Blow-off for quick release

ALTERNATIVE POWER SYSTEMS:

(Specifications may not be as listed. Please contact us for more information.)

- DC power system (MT5HV11DC)
- Air (Venturi) power system (MT5HV11AIRS)

AVAILABLE OPTIONS:

- Individual pad shutoffs (CM1COWB)
- Movable pad mounts (CM2SCM)
- Green lift light (EO2GSL)
- Vacuum loss warning buzzer (EO3VLW)
- Closed cell foam pad rings (FRHV11)
- Voltage adaptation (EO6VA)
- Vacuum package mounting bar (LB5MBO)
 (for use with MT5HV11DC)
- Removable control pendant (EO9RP)
 (Available on MT5HV11DC only)
- Alternative frame dimensions and configurations

Featuring 90° tilt and a high-flow vacuum system, this Powr-Grip® vacuum lifter is designed specifically for lifting, tilting and transferring stone and other high-density materials.



Shown with optional Vacuum Loss Warning Buzzer, Green Lift Light and Individual Pad Shutoffs.

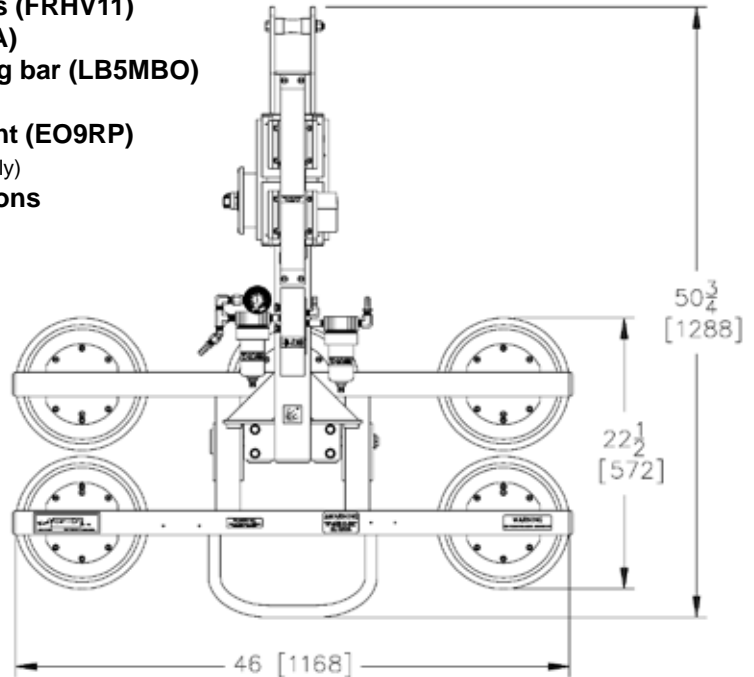
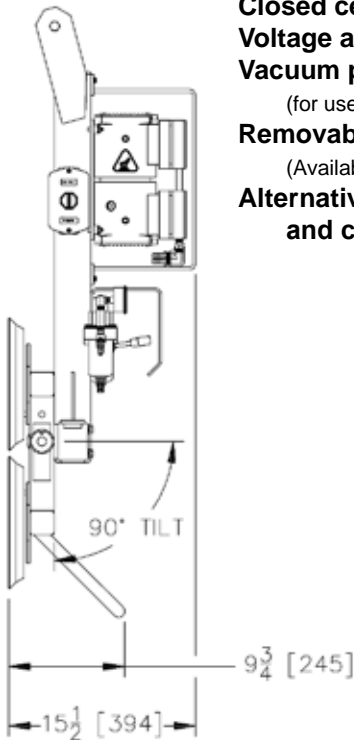

Based on product information at time of publication.

