

## PT10HV11AIR

Standard Pad Spread: 23" x 74" [584 x 1880 mm]  
Number / Size of Pads: 10 / 10" [254 mm] dia. lipped  
Load Capacity: 1500 lbs. [680 kg]

(On smooth, nonporous surfaces.  
Please contact us for recommendations on other surfaces.)

Unit Weight: 320 lbs. [146 kg]  
(for Air Power System)

Standard Operating Power:  
Compressed Air, 11 SCFM [311 liters/min] @ 80 psi [552 kPa]

Apply: 10 sec. Release: 3 sec. (approx.)

Load Movement:  
Power tilt, 90° between upright and flat  
Time for 90° Tilt: 8 sec. (approx.)

Tilt Duty: Continuous  
Vacuum gauge  
Vacuum reserve tank  
Vacuum line filter  
Spring-mounted pads  
Individual shutoffs to all pads  
Closed cell foam pad rings  
Blow-off for quick release

### ALTERNATIVE POWER SYSTEMS:

(See page 2 for specifications.)

AC power system (PT10HV11AC)  
DC power system (PT10HV11DC)

### DESIGN STANDARDS:

ASME B30.20-compliant\* (BTH-1 Design  
Category "B", Service Class "0")  
(\*specify when ordering)

To reduce the risk of load damage, this Powr-Grip® vacuum lifter provides effortless power tilting and optimal support of stone and other high-density materials.



### AVAILABLE OPTIONS:

12-Volt/DC vacuum back-up system (EO1DCB)  
Vacuum loss warning buzzer (EO3VLW)  
Removable control pendant (EO9RP)  
Control handle extensions (LB9HEO)  
Alternative dimensions and configurations of the pad frame, including:  
33" x 74" [838 mm x 1880 mm] (CF9ADO)  
60" x 90" [1524 mm x 2286 mm] (CF9ADO)

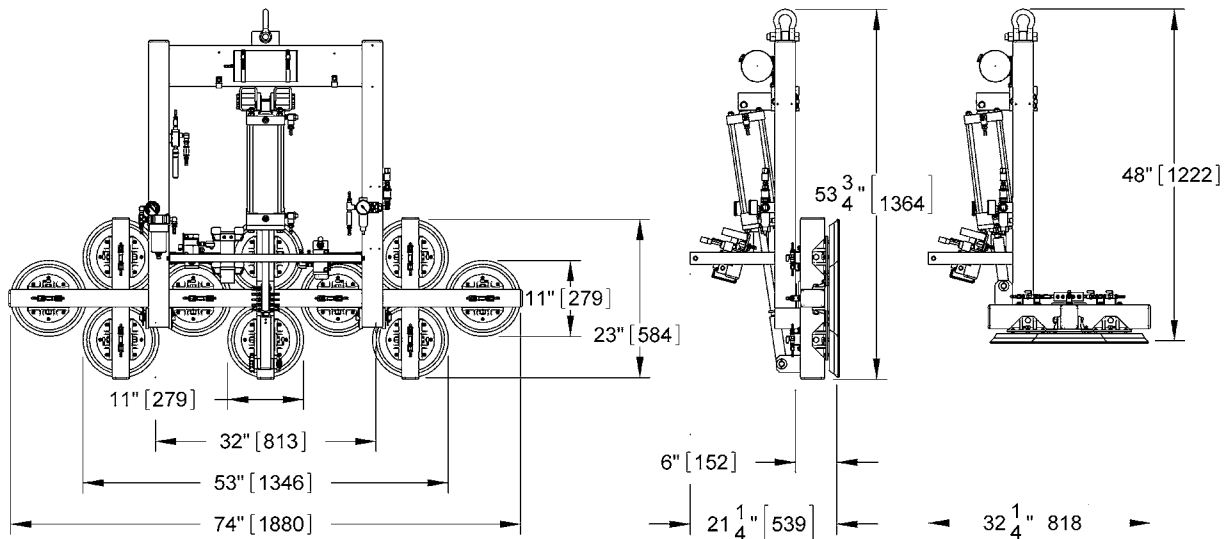

Based on product information at time of publication.

---

# ALTERNATIVE POWER SYSTEMS

## AC POWER SYSTEM

Standard Operating Power: 120 volts AC, 50/60 hertz, 6 amps  
(240 volts AC, 50/60 hertz, 3 amps also available)

Vacuum Pump: Diaphragm type, 3 SCFM [85 liters/min] nominal airflow

Apply: 4 sec. Release: 4 sec. (approx.)

Green lift light

Removable control pendant

Twist-lock electrical plug

Blow-off for quick release

Unit weight: 365 lbs [166 kg]

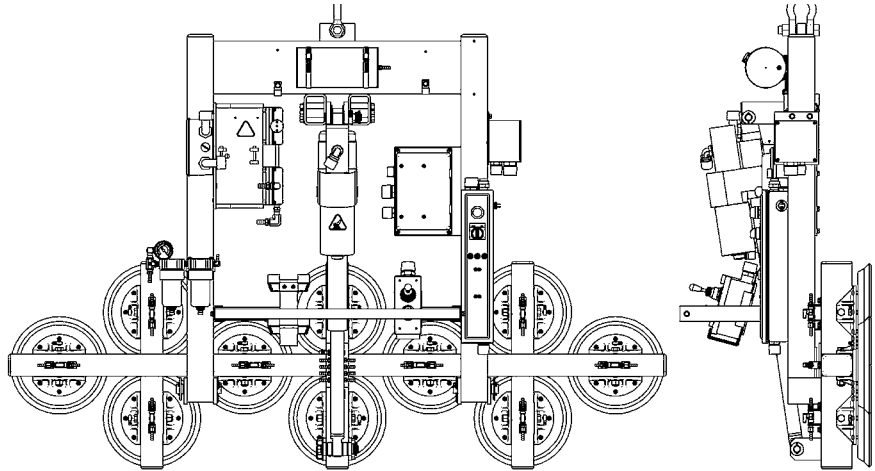

## DC POWER SYSTEM

Standard Operating Power: 12 volts DC, 54 amps

Vacuum Pump: Diaphragm type,  
3 SCFM [85 liters/min] nominal airflow

Apply: 4 sec. Release: 4 sec. (approx.)

On-board battery and charger

Battery energy gauge

Green lift light

Removable control pendant

Blow-off for quick release

Unit weight: 400 lbs [182 kg]

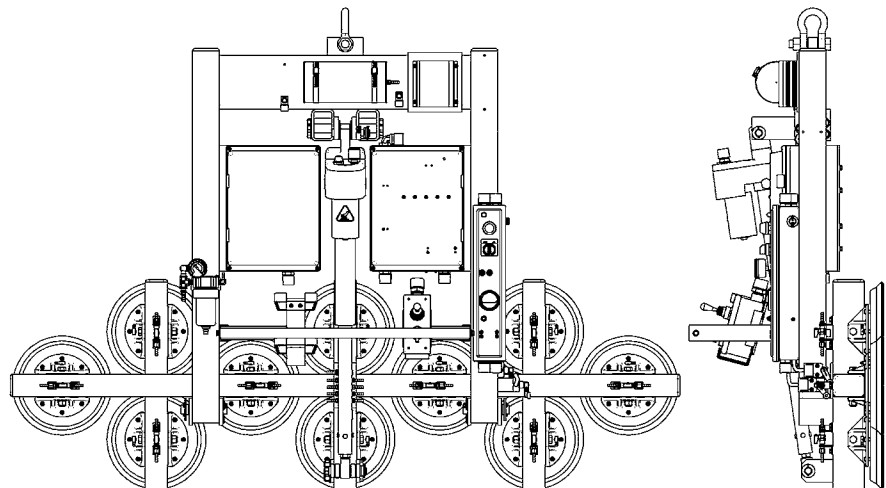

# OPTIONAL FRAME CONFIGURATIONS (CF9ADO)

An Alternative Dimension Pad Frame consists of a specially designed version of the frame used to support the vacuum pads. This option enables a vacuum lifter to handle loads with different dimensions from those of the standard pad frame. In this way, users can tailor their vacuum lifters for specific materials handling applications, without the added time and expense of ordering custom-made equipment. In addition to different overall dimensions, these pad frames may also feature Movable Pad Mounts or Individual Vacuum Pad Shutoffs, depending on the pad frame selected. Custom-made pad frames are also available.

## PT10HV11

**Standard Pad Spread: 33" x 74" [838 mm x 1880 mm]**

**Number / Size of Pads: 10 / 10" [254 mm] dia. lipped**

**Load Capacity: 1500 lbs. [680 kg]**

(On smooth, nonporous surfaces.  
Please contact us for recommendations  
on other surfaces.)

**Unit weight:**

- 340 lbs [155 kg] with Air power system**
- 385 lbs [175 kg] with AC power system**
- 420 lbs [191 kg] with DC power system**

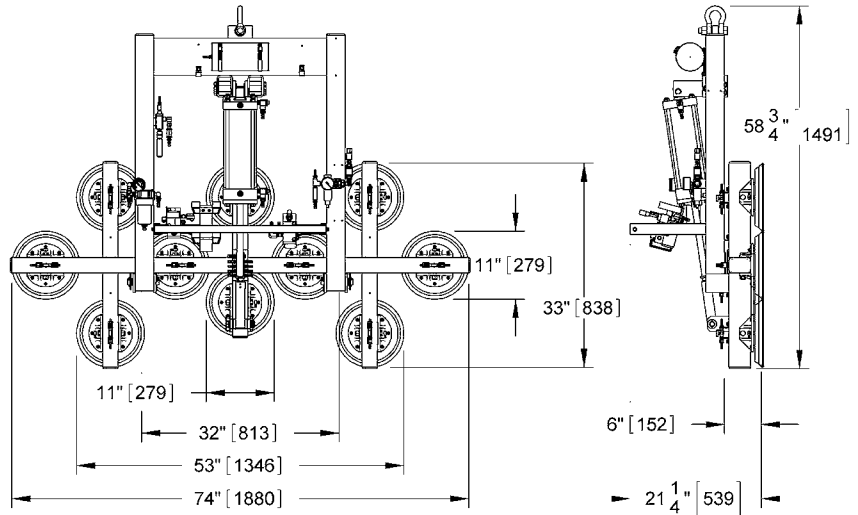

## PT14HV11

**Standard Pad Spread: 60" x 90" [1524 mm x 2286 mm]**

**Number / Size of Pads: 14 / 10" [254 mm] dia. lipped**

**Load Capacity: 1500 lbs. [680 kg]**

(On smooth, nonporous surfaces.  
Please contact us for recommendations on other surfaces.)

**Unit weight:**

- 505 lbs [229 kg] with Air power system**
- 550 lbs [250 kg] with AC power system**
- 585 lbs [266 kg] with DC power system**

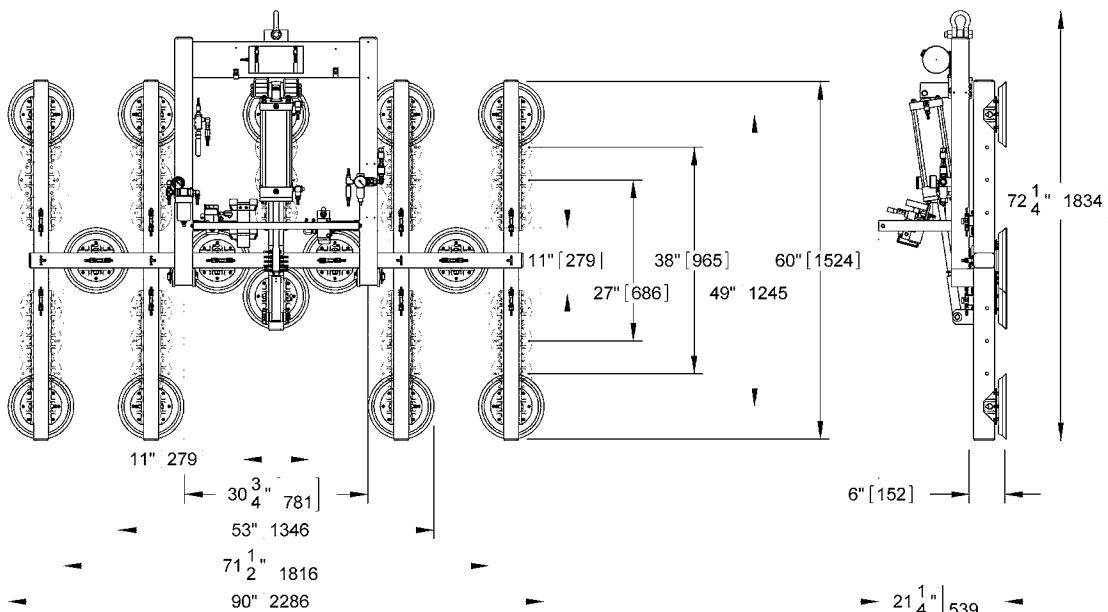

# OPTIONAL HANDLE EXTENSION (LB9HEO)

Control Handle Extensions provide a way to move the control handle a distance of 36" [91 cm] outward from the standard operator position. This enables the operator to maneuver the load and to use the tilt control while remaining safely outside the path of tilting materials. In this way, the operator can handle a very wide load conveniently and efficiently without ever risking contact with the load itself.

