

# DC QUADRA-TILT ROTATOR 1100



## MRTA611LDC

### Standard Pad Spread\*:

- Minimum Width - 12-1/2" [317 mm]
- Maximum Width - 58-3/4" [1491 mm]
- Minimum Length - 46-3/4" [1188 mm]
- Maximum Length - 104-1/2" [2656 mm]

Number / Size of Pads: 6 / 11" [28 cm] dia. lipped

Maximum Load Capacity\*: 1100 lbs [500 kg]

Per-Pad Capacity\*: 184 lbs [83.5 kg]

(On smooth, nonporous surfaces.)

Please contact us for recommendations on other surfaces.)

Unit Weight: 188 lbs [86 kg]

Standard Operating Power: 12 volts DC, 10 amps

### Load Movement:

- Manual rotation, 360° edgewise,  
with automatic locking at each 1/4 revolution.
- Assisted manual tilt, 90° between upright and flat.

### Dual vacuum system

Low vacuum warning light and buzzer

On-board battery and charger

Battery energy gauge

Vacuum gauges

Vacuum line filters

Vacuum reserve tanks

Spring-mounted pads

(Re)movable pad mounts

Extension arms

\* See Frame Configurations  
and Capacities.

### AVAILABLE OPTIONS:

Remote control system (EO8RC1)

Tilt locks (LB8TLO)

Adjustable lift bar extension (LB12AEO)

Alternative vacuum pads:

(Specifications not as listed above.)

Please contact us for more information.)

9" [23 cm] diameter (VPFS9)

10" [25 cm] dia. concave (G0750)

10" [25 cm] dia. lipped (HV11)

Cladding pad frame extensions (CF13CEO)

### DESIGN STANDARDS:

(See [www.powrgrip.com](http://www.powrgrip.com) for more information.)

ASME B30.20

(BTH-1 Design Category "B", Service Class "0")

CE

AS 4991-2004

In addition to Powr-Grip's® Dual Vacuum System, this DC-powered vacuum lifter features our innovative Quadra-Tilt linkage, continuous 360° rotation and a variety of frame configurations, for maximum security and versatility at the construction site or in the shop.



The Quadra-Tilt Lifters feature an innovative four-bar tilt mechanism that significantly reduces the effort of tilting heavy loads between flat and upright positions. This tilt mechanism also reduces hazards associated with lifting loads from upright racks: When a load is tilted to either the upright or the flat position, the lifter maintains the load position automatically without using latches, eliminating the tendency for a load to "kick back" at the operator's knees.

The MRTA611LDC also features a dual vacuum system, 360° manual rotation, (re)movable pads and extension arms that accommodate a variety of load sizes and shapes (see Frame Configurations and Capacities).

The Dual Vacuum System features two vacuum line circuits, allowing the lifter to maintain the vacuum level for one circuit even if an unexpected vacuum loss occurs in the other one. This system is designed to reduce the risk of falling loads, which could result from breakage or other accidents that compromise one area of the vacuum system. In addition, it features audible and visible alarms that warn the operator whenever the vacuum level is not sufficient for lifting the maximum load weight. Complies with CE Standard EN 13155.

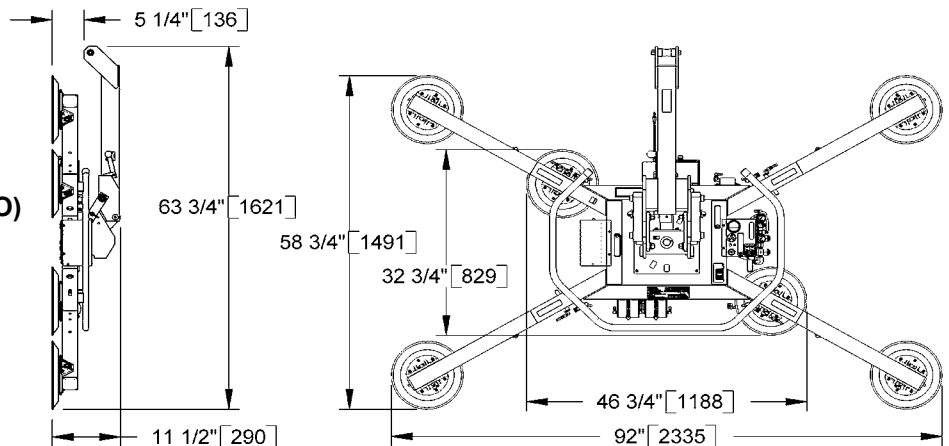

Environmental conditions can affect product performance and longevity; consult the product instructions on [www.powrgrip.com](http://www.powrgrip.com) or contact a Technical Sales Representative for more information. Based on product information at time of publication.

WWW.POWRGRIP.COM

800.548.7341



908 West Main - P.O. Box 368  
Laurel, Montana 59044 U.S.A.  
406.628.8231 (phone) - 406.628.8354 (fax)



Wood's Powr-Grip products are sold through authorized dealers.

Products are manufactured under an ISO 9001 quality management system

Rev. 1.4 / 06-10 Spec. Sheet 8-8



# FRAME CONFIGURATIONS AND CAPACITIES

