

**VLPL49AC**  
**VLPL411LAC**

Attaching to loads in just seconds, these compact vacuum lifters from Wood's Powr-Grip® provide speed and mobility for transferring production materials between upright processing machinery and storage racks.

**Standard Pad Spread:**

VLPL49AC - 30" x 30" [762 x 762 mm]

VLPL411LAC - 33" x 33" [835 x 835 mm]

**Number / Size of Pads:**

VLPL49AC - 4 / 9" [229 mm] diameter

VLPL411LAC - 4 / 11" [280 mm] diameter, lipped

**Load Capacity:**

VLPL49AC - 500 lbs. [225 kg]

VLPL411LAC - 700 lbs. [320 kg]

**Average Unit Weight:** 96 lbs. [44 kg]

**Standard Operating Power:** 480 volts AC, 60 hertz, 2 amps

**Apply:** 1 sec. **Release:** 1 sec. (approx.)

**Load Movement:** Upright to upright

**Green lift light**

**Individual pad shutoffs to upper pads**

**Vacuum gauge**

**Vacuum line filter**

**Spring-mounted pads**

**Twist-lock electrical plug**

**Blow-off for quick release**



**AVAILABLE OPTIONS:**

Vacuum loss warning buzzer (EO3VLW)

Air (venturi) power system (VLPL49AIRS)

Movable control pendant (EO9RP)

Voltage adaptation (EO6VA)

Removable pad arms (CF2EAO)

**DESIGN STANDARDS:**

(See [www.powrgrip.com](http://www.powrgrip.com) for more information.)

**ASME B30.20 - 2006**

(BTH-1 Design Category "B", Service Class "0")

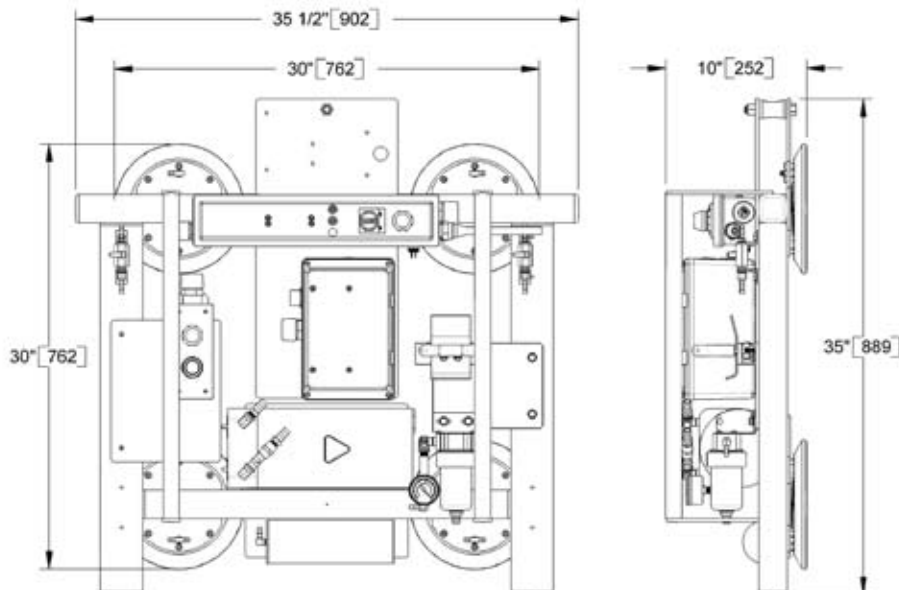

Based on product information at time of publication.

**VLPL611LACS**

**Standard Pad Spread:**

Minimum: 33" x 33" [835 x 835 mm]

Maximum: 33" x 63" [835 x 1597 mm]

**Number / Size of Pads:**

6 / 11" [280 mm] diameter, lipped

**Load Capacity:** 1000 lbs. [455 kg]

**Unit Weight:** 126 lbs. [58 kg]

**Standard Operating Power:**

120 volts AC, 60 hertz, 4 amps

**Apply:** 2 sec. **Release:** 3 sec. (approx.)

**Load Movement:** Upright to upright

**Green lift light**

**Removable pad arms**

**Vacuum gauge**

**Vacuum line filter**

**Spring-mounted pads**

**Twist-lock electrical plug**

**Blow-off for quick release**

Attaching to loads in just seconds, this compact vacuum lifter from Wood's Powr-Grip® provides speed and mobility for transferring production materials between upright processing machinery and storage racks.



**AVAILABLE OPTIONS:**

Vacuum loss warning buzzer (EO3VLW)

Air (venturi) power system (VLPL69AIRS)

Movable control pendant (EO9RP)

Voltage adaptation (EO6VA)

**DESIGN STANDARDS:**

(See [www.powrgrip.com](http://www.powrgrip.com) for more information.)

**ASME B30.20 - 2006**

(BTH-1 Design Category "B", Service Class "0")

