

LJ45PH155
TL6PH155
LJ45PH3025
TL6PH3025

**Instructions for Use,
Maintenance and Care**

Rev. 3.2 / 07-10 Instruction Sheet 32604 **PH**

Gripper
(LJ45PH3025 and TL6PH3025)

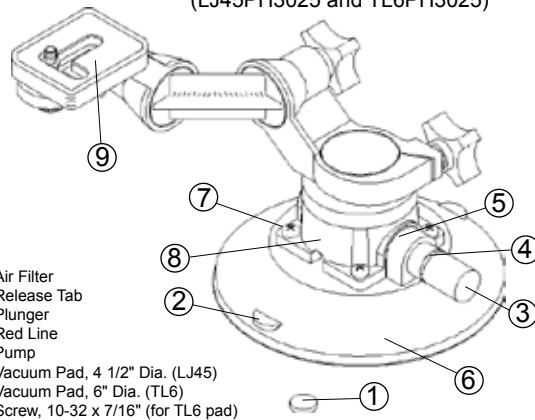

1. 60024 Air Filter
2. Release Tab
3. Plunger
4. Red Line
5. 90111 Pump
6. 49345T Vacuum Pad, 4 1/2" Dia. (LJ45)
49386T Vacuum Pad, 6" Dia. (TL6)
7. 10014 Screw, 10-32 x 7/16" (for TL6 pad)
10024 Screw, 10-32 x 5/8" (for LJ45 pad)
8. 50209 Accessory Mount, Aluminum, 3/8-16 Stud (for Gripper)
50210 Accessory Mount, Aluminum, 1/4-20 Stud (for Nukklehead)
9. 60100 Mounting Head, 3-Dimensional
10. 60101 Mounting Head, Double Ball Joint

- Not Shown
29308 Pad Cover, 4 1/2"
29312 Pad Cover, 6"

Nukklehead
(LJ45PH155 and TL6PH155)

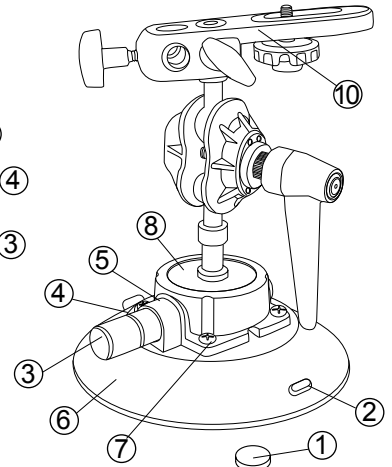

SPECIFICATIONS

Product Description

Vacuum cups use vacuum to mount small loads temporarily, as follows: A manual pump removes air from between the rubber pad and the contact surface; a red line on the pump's plunger serves as a vacuum indicator; a check valve allows the user to repump the cup without removing it from the contact surface; and a release mechanism allows the cup to disengage completely.

Model	Pad	Nominal Dia.	Max. Load Capacity*
LJ45PH155	LJ45	4 1/2" [11 cm]	8.9 lbs [4 kg]
TL6PH155	TL6	6" [15 cm]	8.9 lbs [4 kg]
LJ45PH3025	LJ45	4 1/2" [11 cm]	6.7 lbs [3 kg]
TL6PH3025	TL6	6" [15 cm]	6.7 lbs [3 kg]

*Maximum Load Capacity includes a 3:1 safety factor and requires the following: attachment on clean, smooth, nonporous flat surfaces; a minimum vacuum level of 17 1/2" Hg [-59 kPa]; and a friction coefficient of 1. This rating is based on tests of new vacuum cups attached to static objects in ideal conditions. Many factors can reduce the capacity, such as dynamic loading (eg, mounting loads on moving vehicles) or attaching loads that apply leverage to the cup. See www.powrgrip.com for more information.

Contact Surface and Environmental Conditions

Use the cup on clean, relatively smooth, nonporous surfaces, at temperatures from 0° to 120° Fahrenheit [-18° to 49° Celsius]. Moisture or contaminants can reduce the slip resistance of the cup. The red-line indicator may not perform reliably at elevations above 5000 feet [1524 meters]; see Service.

OPERATION

To Attach

- 1) Clean the contact surface and, if needed, the face of the vacuum cup (see Cleaning). CAUTION: Test the cup for staining or deformation of surfaces with light colors or soft coatings.
- 2) Position the cup so the red line will be visible if it should appear while the cup is attached.
- 3) Pump the plunger until the cup attaches completely. When the red line is hidden, the cup is ready for use.
- 4) Check the plunger frequently to make sure the cup remains securely attached. If the red line appears, pump the plunger until the red line is hidden again (see WARNINGS).

To Release

- 1) Secure the load.
- 2) Pull a release tab until the cup disengages completely. CAUTION: Remove the cup when not in use. If the cup remains attached to a hot surface (eg, in direct sunlight) for an extended time, the rubber pad could bond with the surface, resulting in damage to the surface or to the pad when it is removed.

MAINTENANCE

Service

Regularly make sure the vacuum cup's air filter is in place. If not, discontinue use until the filter is replaced. Since aging and wear reduce the capacity of the rubber pad, it should be replaced at least once every 2 years or whenever damage is discovered. If the cup does not function normally, the cup face may be dirty or damaged, or the pump may require service. First clean the cup face according to the directions to follow. If the problem persists, contact an authorized dealer or visit www.powrgrip.com for assistance.

Cleaning

- 1) Remove the air filter from the cup face.
- 2) Use a clean sponge or lint-free cloth to apply soapy water or another mild cleanser to the cup face; see WARNINGS and www.powrgrip.com for more information. CAUTION: To prevent liquid from contaminating the pump, hold the cup face-down or cover the suction hole in the filter recess.
- 3) Wipe all residue from the cup face.
- 4) Allow the cup to dry and reinstall the air filter.

Storage

Store in a clean, dry location out of direct sunlight. Use the pad cover to protect the cup face from damage.

WARNINGS

- Failure to observe WARNINGS could damage the vacuum cup or the load, or cause injury to the user.
- Do not use the cup to support loads that exceed the Maximum Load Capacity or the effective capacity (see SPECIFICATIONS).
 - Do not use the cup to support a person.
 - Do not use the cup to support loads which could injure people if the cup disengages unexpectedly.
 - Do not place the cup face against surfaces which could damage the sealing edge of the rubber pad.
 - Avoid conditions that could cause the cup to slip or to disengage prematurely, such as: contaminants, cuts or scratches in the cup face or contact surface; applying the cup to porous materials; or applying pressure against the cup edge.
 - Do not use the cup when the red line is visible. If the red line reappears frequently, discontinue use and see Service.
 - Do not allow anything to interfere with free movement of the plunger while the cup is attached.
 - Do not touch any release tab while using the cup.
 - Do not leave the cup in use and unattended.
 - Do not use harsh chemicals (such as solvents or gasoline) or unauthorized rubber cleaners and conditioners to clean the cup.